

# Counterpoint 1.0-1.1

reference series



Counterpoint 1.0-1.1 sets the highest standards for the delivery of music and has the performance to enable the finest of sounds from an audio system. At its core is the use of a new high performance 'audio surface platform' which is used on all levels, ensuring consistency across the system. A further feature is the development of a fixed 'coupled' or isolated 'decoupled' arrangement that is selectable for each level, 1.0 or 1.1.

The structural frame of the Counterpoint series is considerable and robust, with legs and frame machined from high grade aluminium ensuring its capacity and longevity of use. Throughout the design damping techniques are thoroughly employed maintaining its minimal resonance. This quality and integrity of build enables the Counterpoint series to be a 'total' modular design for the adjustment of spacings and the addition of levels at any time, but also for the connection of adjacent stands when required.

For finish, platforms are available in a selection of premium grade veneers with finely UK applied lacquers, or the finest modern laminates for a slick effect. Aluminium parts available in black or silver.

Finishes: Oak. Black Oak. Walnut. Flat black. Gloss white

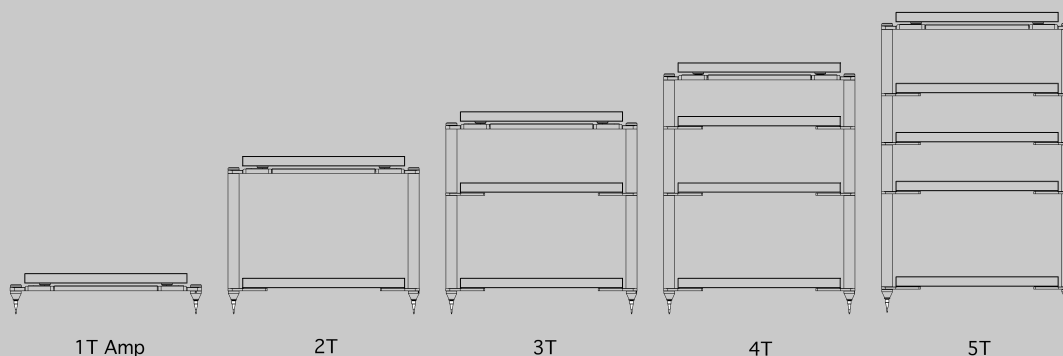

1T Amp  
2T  
3T  
4T  
5T

Audio Surface size - 560(w) x 450(d)  
Modular - vertical and horizontal system  
Leg spacing options - 160mm, 220mm, 320mm, 440mm  
Weight Capacity - +50kg per level

Counterpoint 1.0-1.1  
reference series